



Stage insert for 4 slides optionally available

## Scanning Stage SCAN<sup>plus</sup> 130 × 85 with Integrated Measuring System

### Specifications

Travel range	max. 130 × 85 mm
Travel speed	max. 240 mm/s (with 4 mm ball screw pitch)
Repeatability	< 1 µm (bi-directional) <sup>1</sup>
Accuracy	±1 µm <sup>1</sup>
Resolution	0.05 µm (smallest step size)
Orthogonality	< 10 arcsec
Motor	2-phase stepper motor
Limit switches	continuously adjustable optical light beams
Material / surface	aluminium / anodic coating, black lacquered
Weight	ca. 4.5 kg (without stage insert)

### Order Information

Order No.: 00-24-651-0000  
(4 mm ball screw pitch)

### Product Features

- ▶ **highest accuracy** through integrated linear measuring system
- ▶ flat, ergonomic design enables **easy loading** of the scanning stage
- ▶ plain surface for **easy cleaning**
- ▶ **exchangeable stage inserts for different kinds of applications**, also for well plates or 4 slides
- ▶ continuously adjustable optical light beams for **individual travel range limitation**
- ▶ integrated electronic identification plate ETS for **automatic identification of the scanning stage**
- ▶ **5 years guarantee**, if the scanning stage is operated in the system with the Märzhäuser TANGO controller

### Accessories

Glass plate (included in delivery)  
Order No.: 48-24-520-0810

Stage insert for 4 slides 76 × 26 mm (3" × 1")  
Order No.: 48-24-520-3000

For further accessories please visit:  
[www.marzhauser.com](http://www.marzhauser.com)

### Dimensions

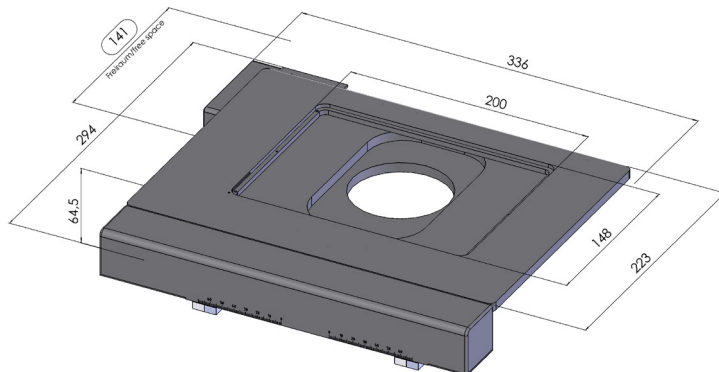

Width depending on the selected stage connection